

Art.	Serbatoio	Pompa	Esecuzione motore	Apparecchiatura elettrica	C	D	E	F	H	Peso	Accessori
	Litri	Mod.	Volt	art.						Kg	Filtro art.
DO 06 VTS 2	6	VTS 2	3 ~ 230/400-50Hz	DO 06 92	60	220	135	181	230	14.8	FB 10 / FC 10
DO 06 VTS 2 M	6	VTS 2 M	1 ~ 230-50Hz	DO 06 90	60	220	135	181	230	15.0	FB 10 / FC 10
DO 06 VTS 4	6	VTS 4	3 ~ 230/400-50Hz	DO 06 92	60	253	135	191	230	16.3	FB 10 / FC 10
DO 06 VTS 4 M	6	VTS 4 M	1 ~ 230-50Hz	DO 06 90	60	253	135	191	230	16.5	FB 10 / FC 10
DO 06 VTS 6	6	VTS 6	3 ~ 230/400-50Hz	DO 06 92	60	270	135	216	230	21.3	FB 10 / FC 10
DO 06 VTS 6 M	6	VTS 6 M	1 ~ 230-50Hz	DO 06 90	60	270	135	216	230	21.5	FB 10 / FC 10
DO 06 VTS 6 CC	6	VTS 6 CC	= 24-CC	DO 06 93	60	290	135	253	230	18.8	FB 10 / FC 10
DO 10 VTS 2	10	VTS 2	3 ~ 230/400-50Hz	DO 06 92	100	220	175	221	270	19.0	FB 10 / FC 10
DO 10 VTS 2 M	10	VTS 2 M	1 ~ 230-50Hz	DO 06 90	100	220	175	221	270	19.2	FB 10 / FC 10
DO 10 VTS 4	10	VTS 4	3 ~ 230/400-50Hz	DO 06 92	100	253	175	231	270	20.5	FB 10 / FC 10
DO 10 VTS 4 M	10	VTS 4 M	1 ~ 230-50Hz	DO 06 90	100	253	175	231	270	20.7	FB 10 / FC 10
DO 10 VTS 6	10	VTS 6	3 ~ 230/400-50Hz	DO 06 92	100	270	175	256	270	25.5	FB 10 / FC 10
DO 10 VTS 6 M	10	VTS 6 M	1 ~ 230-50Hz	DO 06 90	100	270	175	256	270	25.7	FB 10 / FC 10
DO 10 VTS 6 CC	10	VTS 6 CC	= 24-CC	DO 06 93	100	290	175	293	270	21.2	FB 10 / FC 10

Sono disponibili i disegni 3D sul sito www.vuotecnica.net

MINIDEPRESSORI DO 06 ... e DO 10 ...

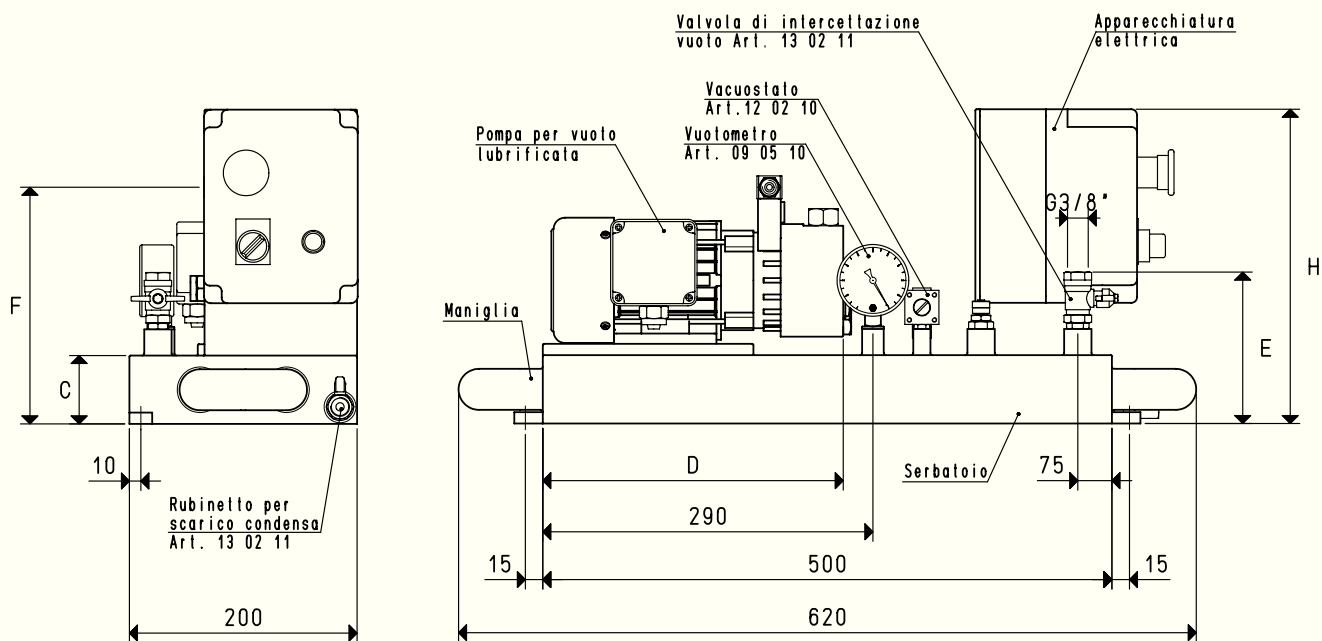
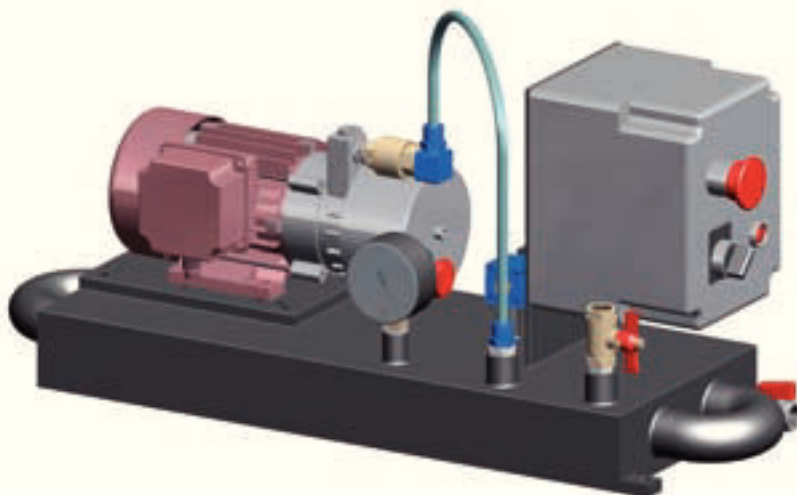

Sono disponibili i disegni 3D sul sito www.vuototecnica.net

Art.	Serbatoio Litri	Pompa Mod.	Esecuzione motore Volt	Apparecchiatura elettrica art.	C	D	E	F	H	Peso Kg	Accessori Filtro art.
DO 06 VTL 2	6	VTL 2	3 ~ 230/400-50Hz	DO 06 92	60	300	135	198	230	15.2	FB 10 / FC 10
DO 06 VTL 2 M	6	VTL 2 M	1 ~ 230-50Hz	DO 06 90	60	300	135	198	230	15.5	FB 10 / FC 10
DO 06 VTL 4	6	VTL 4	3 ~ 230/400-50Hz	DO 06 92	60	330	135	198	230	16.8	FB 10 / FC 10
DO 06 VTL 4 M	6	VTL 4 M	1 ~ 230-50Hz	DO 06 90	60	330	135	198	230	17.0	FB 10 / FC 10
DO 06 VTL 5	6	VTL 5	3 ~ 230/400-50Hz	DO 06 92	60	260	135	310	230	24.0	FB 10 / FC 10
DO 06 VTL 5 M	6	VTL 5 M	1 ~ 230-50Hz	DO 06 90	60	260	135	310	230	24.5	FB 10 / FC 10
DO 06 VTL 6 CC	6	VTL 6 CC	= 24-CC	DO 06 93	60	290	135	260	230	19.8	FB 10 / FC 10
DO 10 VTL 2	10	VTL 2	3 ~ 230/400-50Hz	DO 06 92	100	300	175	238	270	19.4	FB 10 / FC 10
DO 10 VTL 2 M	10	VTL 2 M	1 ~ 230-50Hz	DO 06 90	100	300	175	238	270	19.7	FB 10 / FC 10
DO 10 VTL 4	10	VTL 4	3 ~ 230/400-50Hz	DO 06 92	100	330	175	238	270	21.0	FB 10 / FC 10
DO 10 VTL 4 M	10	VTL 4 M	1 ~ 230-50Hz	DO 06 90	100	330	175	238	270	21.2	FB 10 / FC 10
DO 10 VTL 5	10	VTL 5	3 ~ 230/400-50Hz	DO 06 92	100	260	175	350	270	28.2	FB 10 / FC 10
DO 10 VTL 5 M	10	VTL 5 M	1 ~ 230-50Hz	DO 06 90	100	260	175	350	270	28.7	FB 10 / FC 10
DO 10 VTL 6 CC	10	VTL 6 CC	= 24-CC	DO 06 93	100	290	175	260	270	24.0	FB 10 / FC 10