

DEPRESSORI ORIZZONTALI D0 25 ...

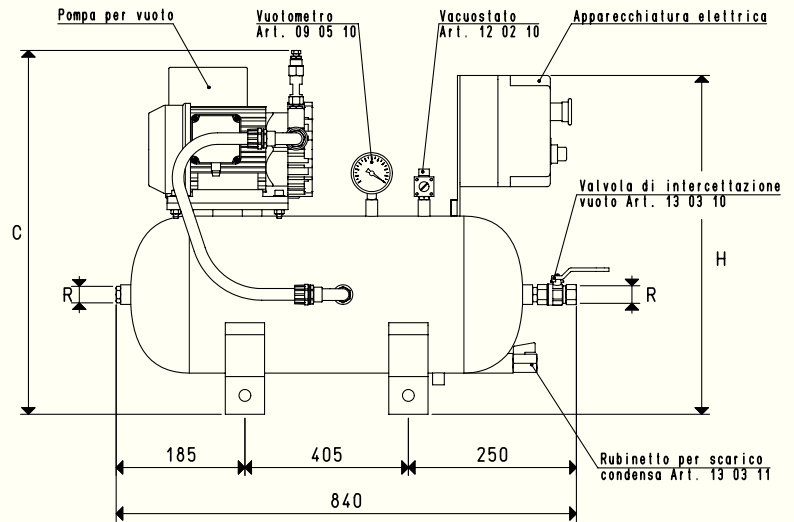

Art.	Serbatoio Litri	Pompa Mod.	Esecuzione motore Volt	Apparecchiatura elettrica art.	C	H	R	Peso Kg	Accessori Filtro art.
DO 25 VTL 5	25	VTL 5	3 ~ 230/400-50Hz	DO 06 92	540	450	G1/2"	33.5	FB 20 / FC 20
DO 25 VTL 5 M	25	VTL 5 M	1 ~ 230/50Hz	DO 06 90	540	450	G1/2"	34.0	FB 20 / FC 20
DO 25 VTL 6 CC	25	VTL 6 CC	= 24-CC	DO 06 93	480	450	G1/2"	29.3	FB 20 / FC 20
DO 25 VTL 10	25	VTL 10	3 ~ 230/400-50Hz	DO 06 92	540	450	G1/2"	39.5	FB 20 / FC 20
DO 25 VTL 10 M	25	VTL 10 M	1 ~ 230-50Hz	DO 06 90	540	450	G1/2"	40.0	FB 20 / FC 20

N.B. Aggiungendo all'articolo le lettere SR, il depressore viene fornito con ruote per consentirne la mobilità (Esempio: DO 25 VTL 10 SR).

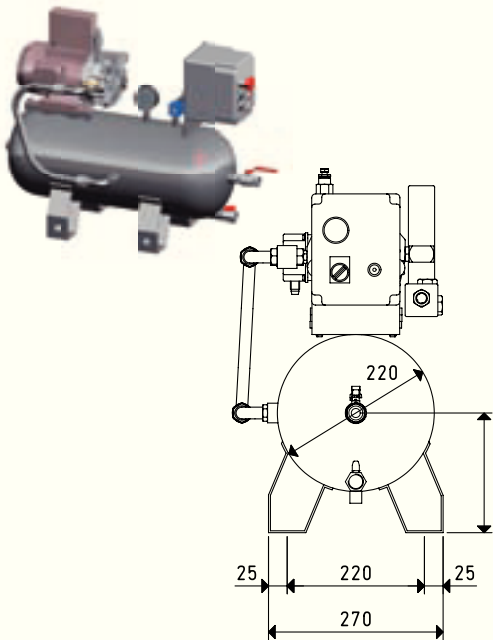

DEPRESSORI ORIZZONTALI D0 50 ...

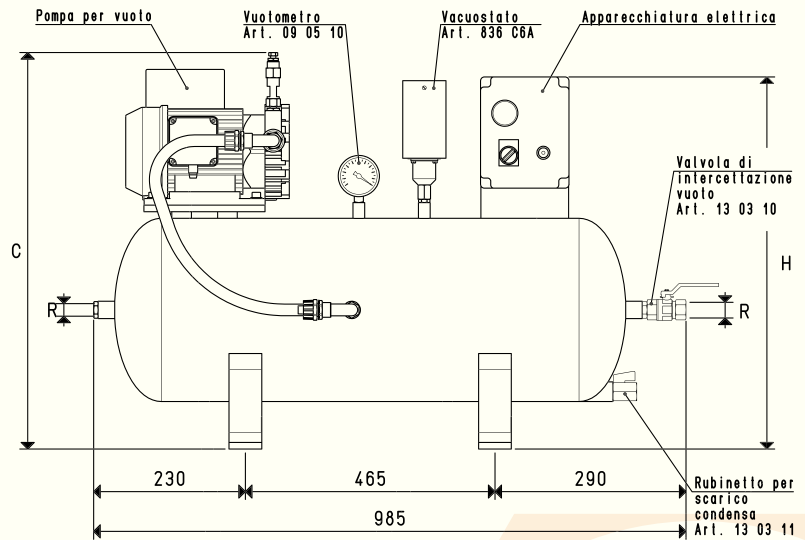
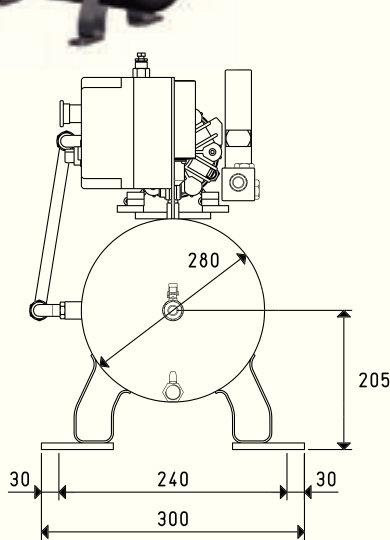

Art.	Serbatoio Litri	Pompa Mod.	Esecuzione motore Volt	Apparecchiatura elettrica art.	C	H	R	Peso Kg	Accessori Filtro art.
DO 50 VTL 5	50	VTL 5	3 ~ 230/400-50Hz	DO 06 92	620	530	G1/2"	39.3	FB 20 / FC 20
DO 50 VTL 5 M	50	VTL 5 M	1 ~ 230/50Hz	DO 06 90	620	530	G1/2"	39.8	FB 20 / FC 20
DO 50 VTL 6 CC	50	VTL 6 CC	= 24-CC	DO 06 93	570	530	G1/2"	35.1	FB 20 / FC 20
DO 50 VTL 10	50	VTL 10	3 ~ 230/400-50Hz	DO 06 92	620	530	G1/2"	45.3	FB 20 / FC 20
DO 50 VTL 10 M	50	VTL 10 M	1 ~ 230-50Hz	DO 06 90	620	530	G1/2"	45.8	FB 20 / FC 20

N.B. Aggiungendo all'articolo le lettere SR, il depressore viene fornito con ruote per consentirne la mobilità (Esempio: DO 50 VTL 10 SR).