

FLANGED FIXING SUPPORT, FOR OCTOPUS SYSTEMS WITHOUT VACUUM GENERATOR

The fixing supports described in this page have been designed to connect an OCTOPUS system to a remotely installed vacuum generator or to an alternative vacuum source.

The anodised aluminium supports are provided with two flanges: one to fix the OCTOPUS system instead of the vacuum generator and the other to connect it to the machine.

They are also equipped with connectors for direct connection to the OCTOPUS system, to the generator or to the alternative vacuum source, as well as to the vacuum level reading and control devices. The unused connections may be closed with special metal caps which they are equipped with.

The flanged fixing supports are currently available in the versions described in this page and are suited for OCTOPUS systems that use the vacuum generators indicates next to the article:

- Art. SO 00 02 PVP 100 ÷ 200M
- Art. SO 00 05 PVP 150 ÷ 300MD
- Art. SO 00 06 PVP 450 ÷ 600MD

Note: The vacuum gauges and switches in the picture are not integral part of the supports.

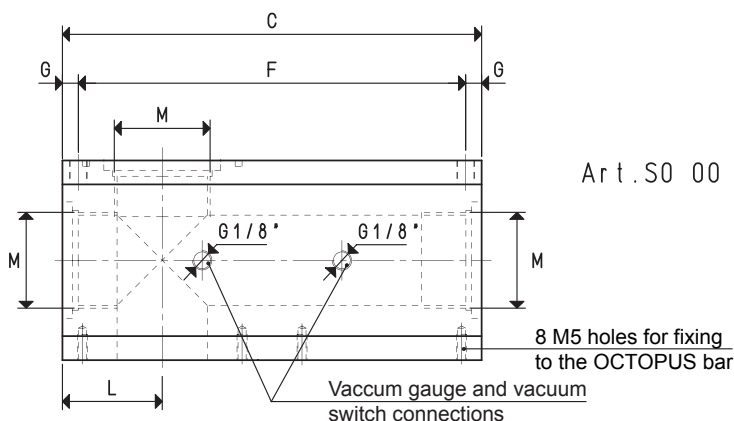
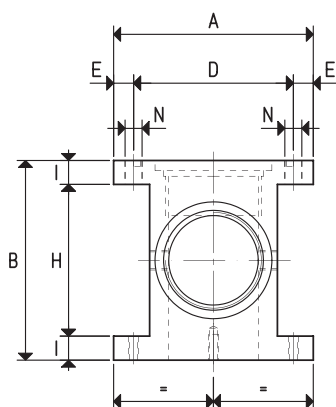

Art. SO 00 02

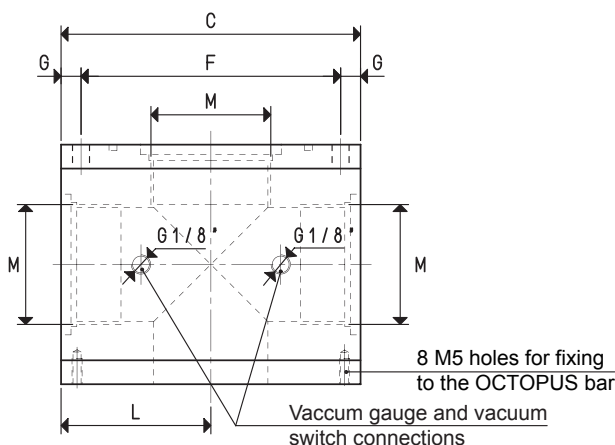
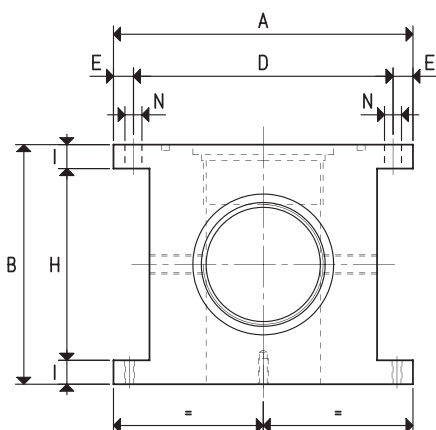

Art. SO 00 05
Art. SO 00 06

3D drawings available at www.vuototecnica.net

Art.	A	B	C	D	E	F	G	H	I	L	M	N	Weight
											Ø	Ø	Kg
SO 00 02	100	100	210	80	10	194	8	76	12	50	G1" 1/2	8.5	2.8
SO 00 05	150	120	150	130	10	134	8	96	12	75	G2"	8.5	4.2
SO 00 06	150	145	150	130	10	134	8	121	12	75	G2" 1/2	8.5	4.3