

Garra Paralela de 3 Dedos - Série CHS3

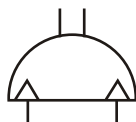

CHS3 -

Modelo



Exemplo: CHS3-32D
CHS3-125D

Diâmetro (mm)		Atuação	
16	50	D	Dupla Ação
20	63	R	Retorno Mola
25	80		
32	100		
40	125		

Diâmetro (mm)	16	20	25	32	40	50	63	80	100	125	
Fluído	Ar										
Pressão de trab. (Bar)	2 à 6				1 à 6						
Temp. ambiente (C)	-10 à + 60										
Repetibilidade (mm)	0.01										
Máx. freq. de trab. (c.p.m)	120				60				30		
Lubrificação	Não necessária										
Atuação	Dupla Ação										
Força efetiva (N) à 5 Bar	Externa	14	25	42	74	118	187	335	500	750	1270
	Interna	16	28	47	82	130	204	359	525	780	1320
Curso abrir/fechar (mm)	4	4	6	8	8	12	16	20	24	32	

Nota: Para Ø16 à 20mm o valor de L = 20mm, para Ø32 à 63mm o valor de L = 30mm, para Ø80 à 125mm o valor de L = 50mm. O valor L é em relação a Força efetiva.

Sensor e Kit de Reparo

SM -



Modelo	
07	Cil. Ø16~25
32	Cil. Ø32~125

Tipo	
R	Reed (2 fios)
P	PNP (3 fios)
N	NPN (3 fios)

Cabo	
M8	Conector M8
2M	2 metros



SM-07
(Ø16 à 25mm)



SM-32
(Ø32 à 125mm)

Exemplo: SM-07R-2M
SM-32P-M8

Kit de Reparo				
Ø da Garra	Código	Ø da Garra	Código	Compõe o kit
16	KR-CHS316	50	KR-CHS350	Vedações do êmbolo.
20	KR-CHS320	63	KR-CHS363	
25	KR-CHS325	80	KR-CHS380	
32	KR-CHS332	100	KR-CHS3100	
40	KR-CHS340	125	KR-CHS3125	

Ponto de aperto

- A peça de trabalho e a distância do ponto de aperto devem estar dentro das faixas de força de prensão dadas para cada pressão nos gráficos de força eficazes.
- Se operado com o ponto de fixação da peça de trabalho além das faixas indicadas, e carga de compensação excessiva aplicada à secção de deslizamento dos dedos, isso pode ter um efeito adverso sobre o período de vida do produto.

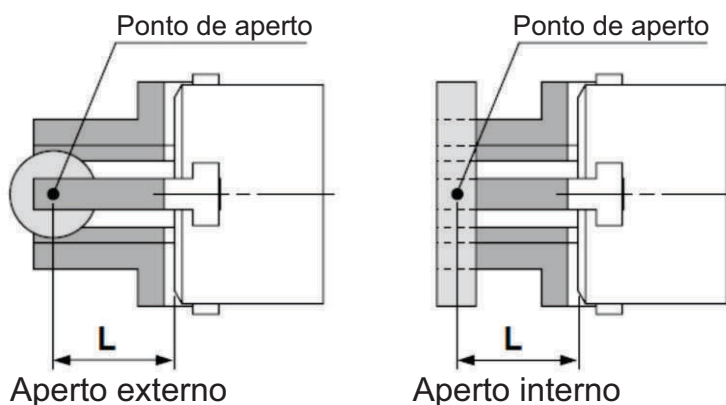

L: Distância do ponto de aperto

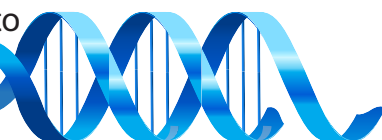

Força efetiva de aperto

Aperto externo

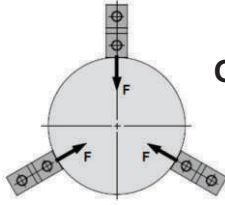

Obs: 0.1 Mpa = 1 Bar = 14.5 PSI

Aperto Interno

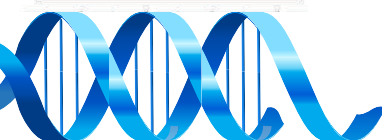
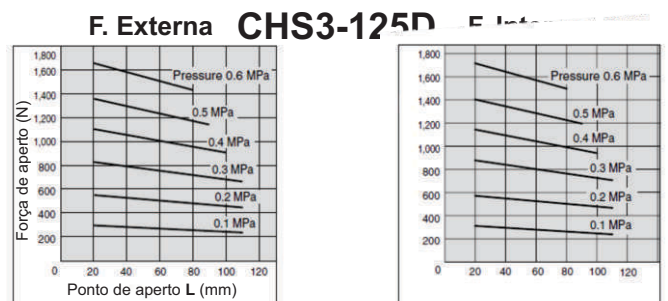
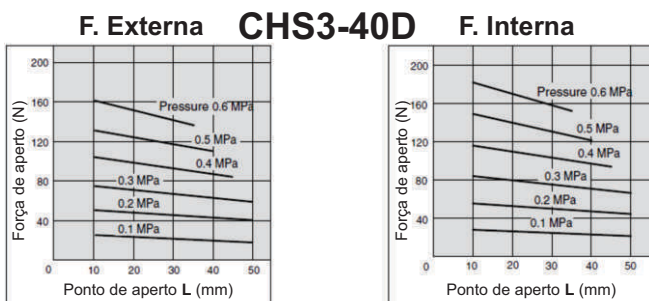
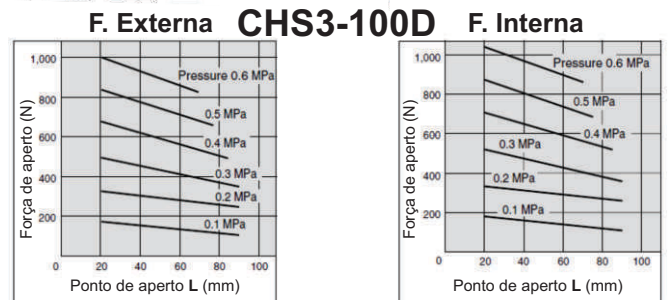
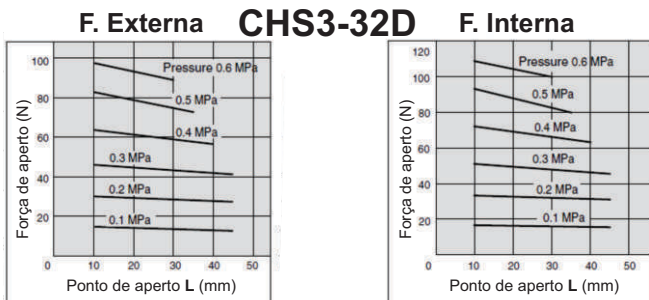
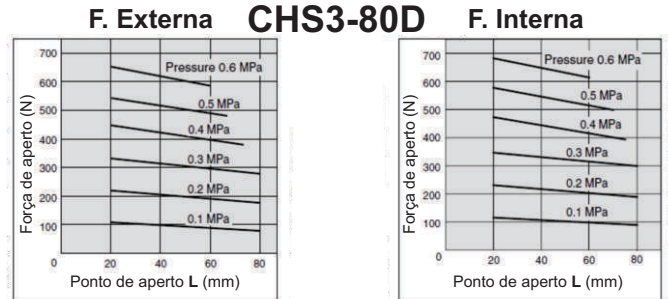
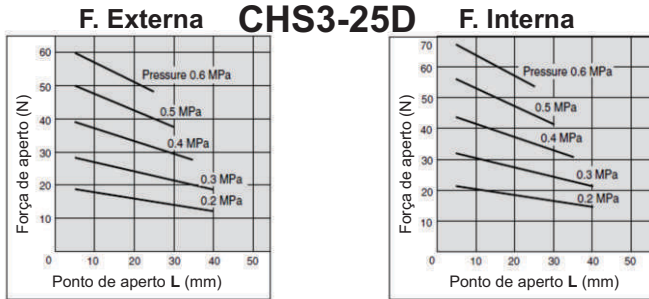
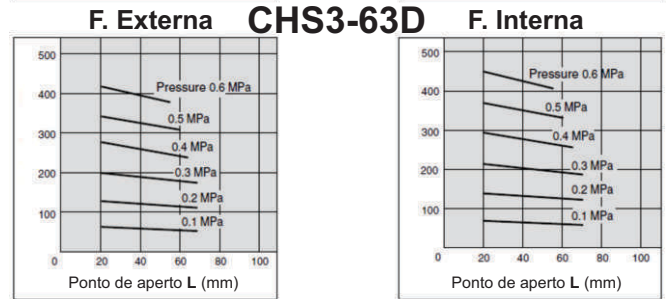
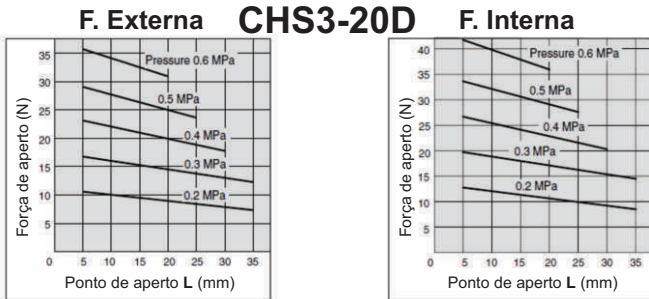
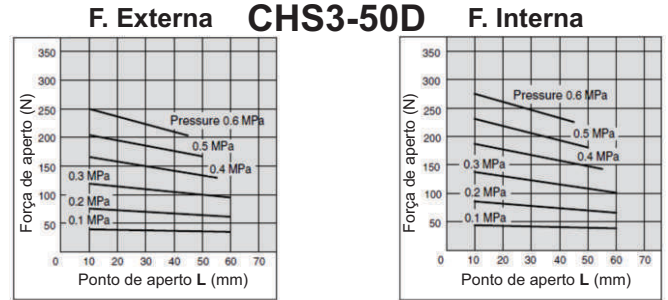
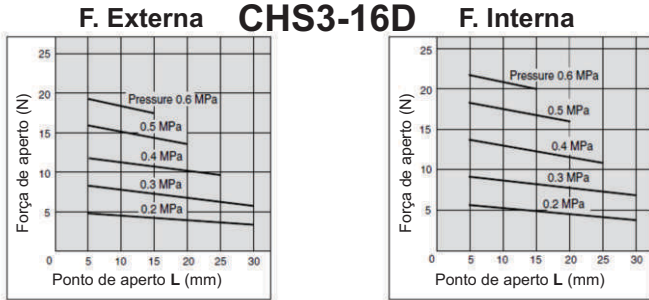
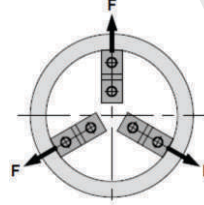

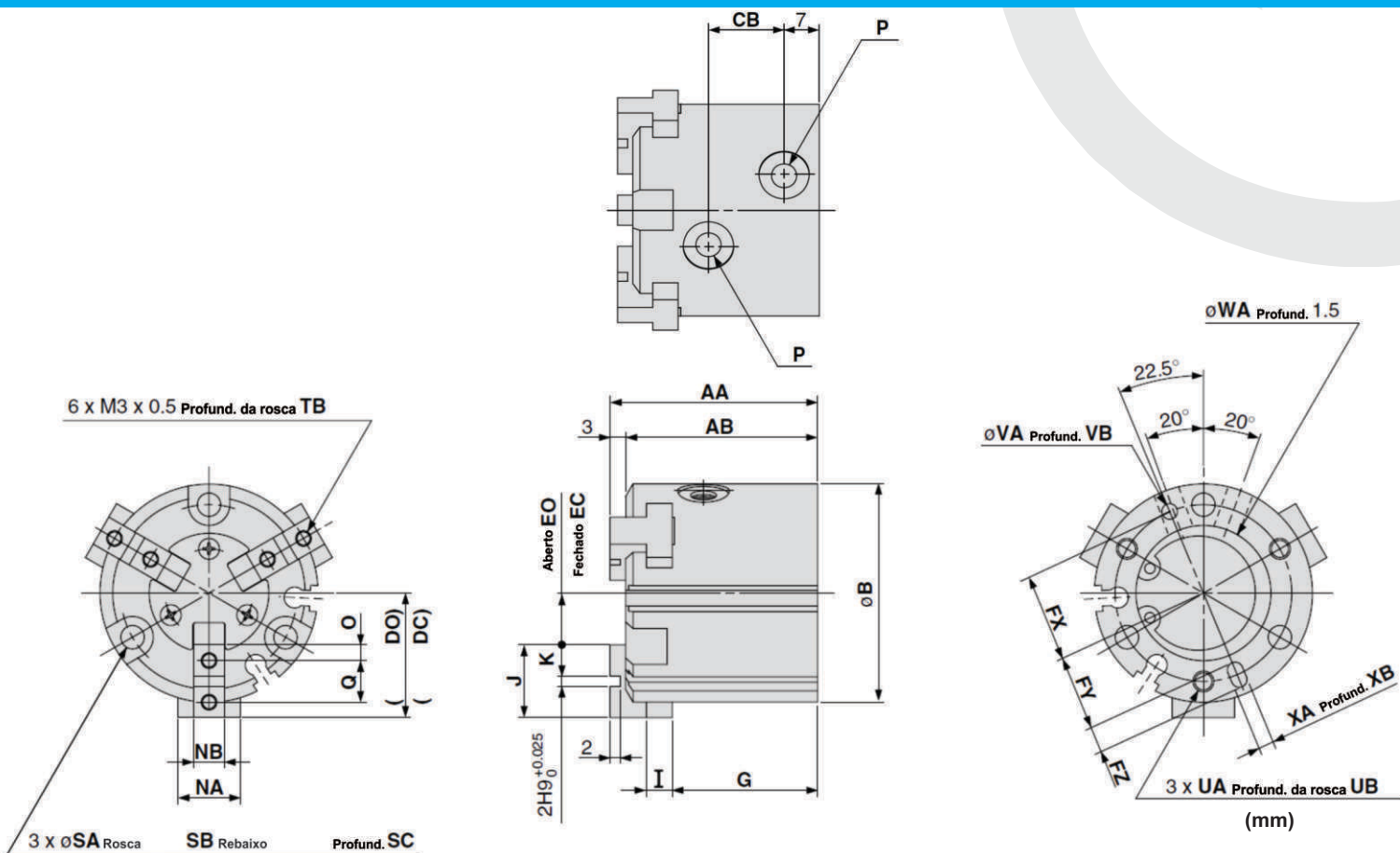
Dimensional

Modelo	AA	AB	B	CB	DC	DO	EC	EO	FX	FY	FZ	G	I	J	K	NA	NB	O	P	Q	R
CHS3-16D	35	32	30	11	15	17	5	7	12.5	11	3	25	4	10	4	8	5h9	2	M3 x 0.5	6	25
CHS3-20D	38	35	36	13	18	20	6	8	14.5	13	3	27	5	12	5	10	6h9	2.5	M5 x 0.8	7	29
CHS3-25D	40	37	42	15	21	24	7	10	17	14.5	5	28	5	14	6	12	6h9	3	M5 x 0.8	8	34

Modelo	SA	SB	SC	TB	UA	UB	VA	VB	WA	XA	XB
CHS3-16D	3.4	6.5	8	5	M3 x 0.5	4.5	2H9	2	17H9	2H9	2
CHS3-20D	3.4	6.5	9.5	6	M3 x 0.5	6	2H9	2	21H9	2H9	2
CHS3-25D	4.5	8	10	6	M4 x 0.7	6	3H9	3	26H9	3H9	3

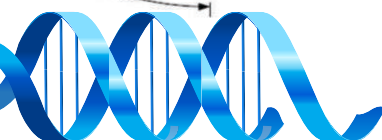
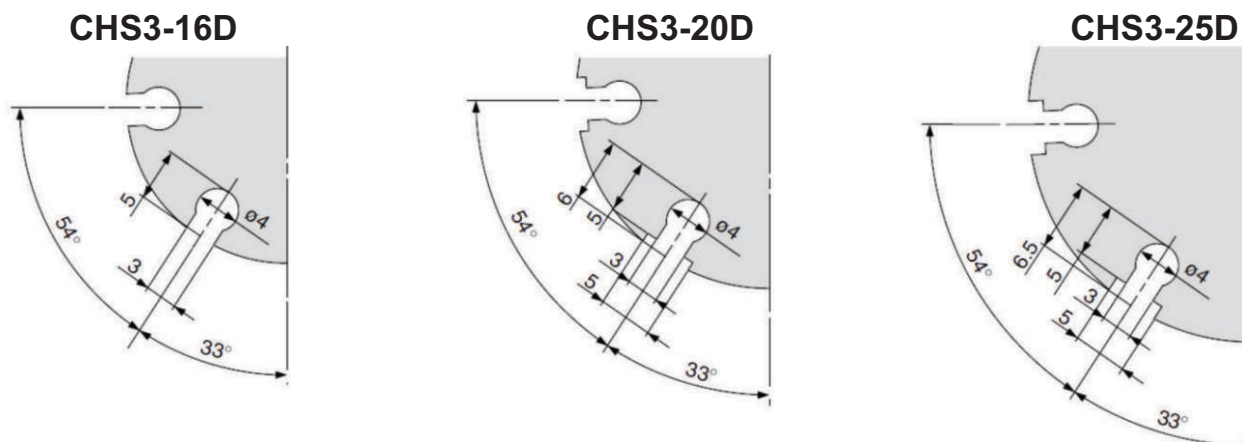
Dimensional - Canal do sensor

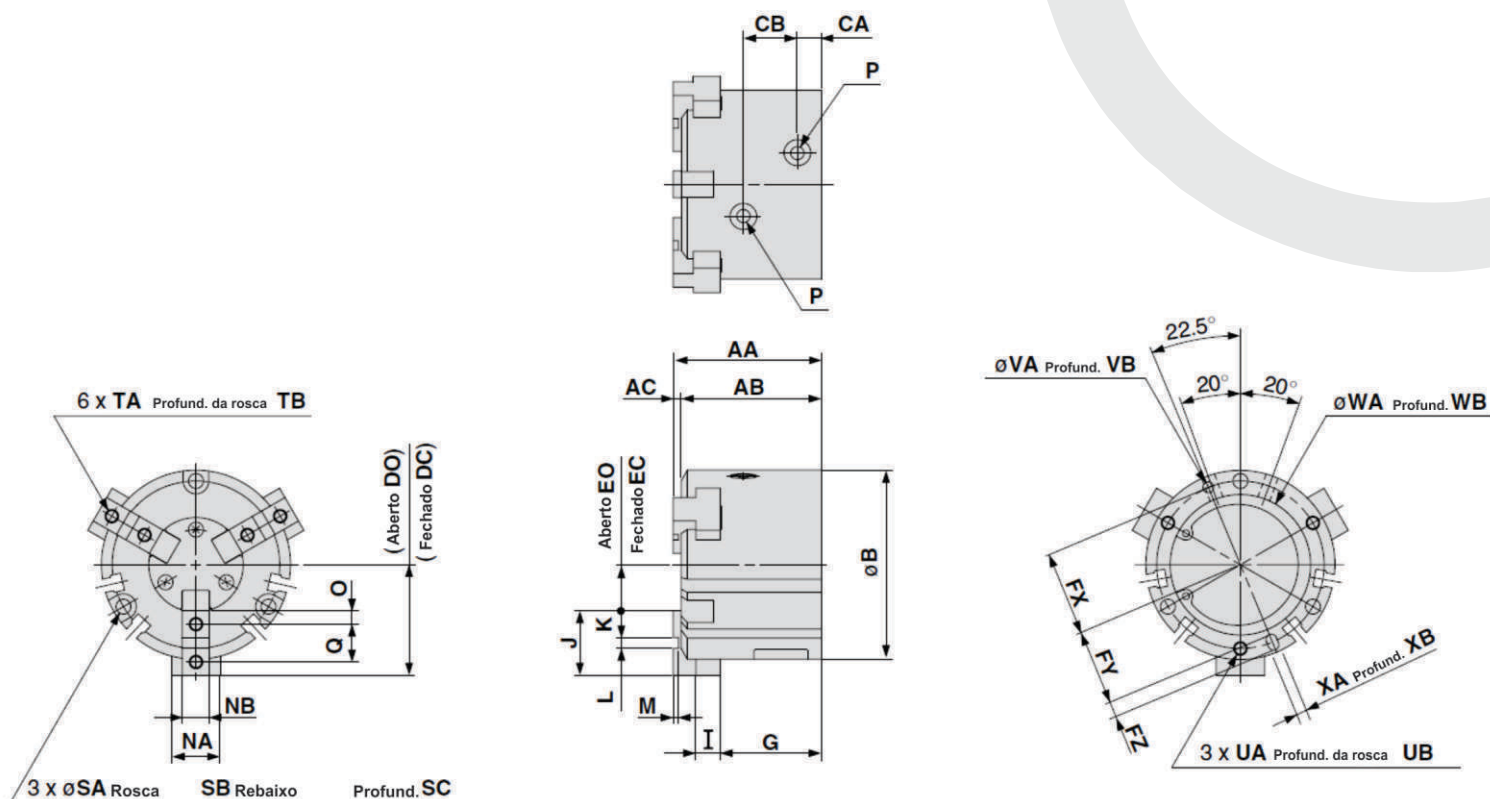
Dimensional

(mm)

Modelo	AA	AB	AC	B	CA	CB	DC	DO	EC	EO	FX	FY	FZ	G	I	J	K	L	M	NA	NB
CHS3-32D	44	41	3	52	8	16	28	32	8	12	22	19.5	5	30.5	6	20	9	2H9	2	14	8h9
CHS3-40D	47	44	3	62	9	17	31	35	10	14	26.5	23.5	6	32	7	21	9	3H9	2	16	8h9
CHS3-50D	55	52	3	70	9	20	35	41	11	17	31	28	6	37.5	9	24	10	4H9	2	18	10h9
CHS3-63D	66	62	4	86	12	22	43	51	15	23	38	34.5	7	44	11	28	11	6H9	3	24	12h9
CHS3-80D	82	77	5	106	13.5	27	53.5	63.5	21.5	31.5	47.5	43.5	8	56	12	32	12	8H9	4	28	14h9

Modelo	O	P	Q	R	SA	SB	SC	TA	TB	UA	UB	VA	VB	WA	WB	XA	XB	Y
CHS3-32D	4.5	M5 x 0.8	11	44	4.5	8	9	M4 x 0.7	8	M4 x 0.7	6	3H9	3	34H9	2	3H9	3	6
CHS3-40D	4.5	M5 x 0.8	12	53	5.5	9.5	9	M4 x 0.7	8	M4 x 0.7	7.5	4H9	4	42H9	2	4H9	4	8
CHS3-50D	5	M5 x 0.8	14	62	5.5	9.5	12	M5 x 0.8	10	M5 x 0.8	10	4H9	4	52H9	2	4H9	4	7
CHS3-63D	5.5	M5 x 0.8	17	76	6.6	11	14	M5 x 0.8	10	M6 x 1	9	5H9	5	65H9	2.5	5H9	5	7.5
CHS3-80D	6	G 1/8"	20	95	6.6	11	19	M6 x 1	12	M6 x 1	12	6H9	6	82H9	3	6H9	6	8

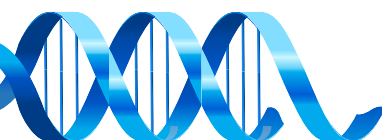
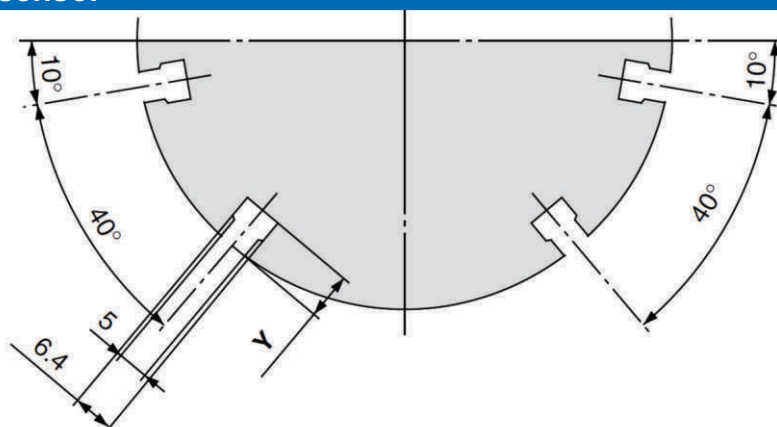
Dimensional - Canal do sensor

Dimensional

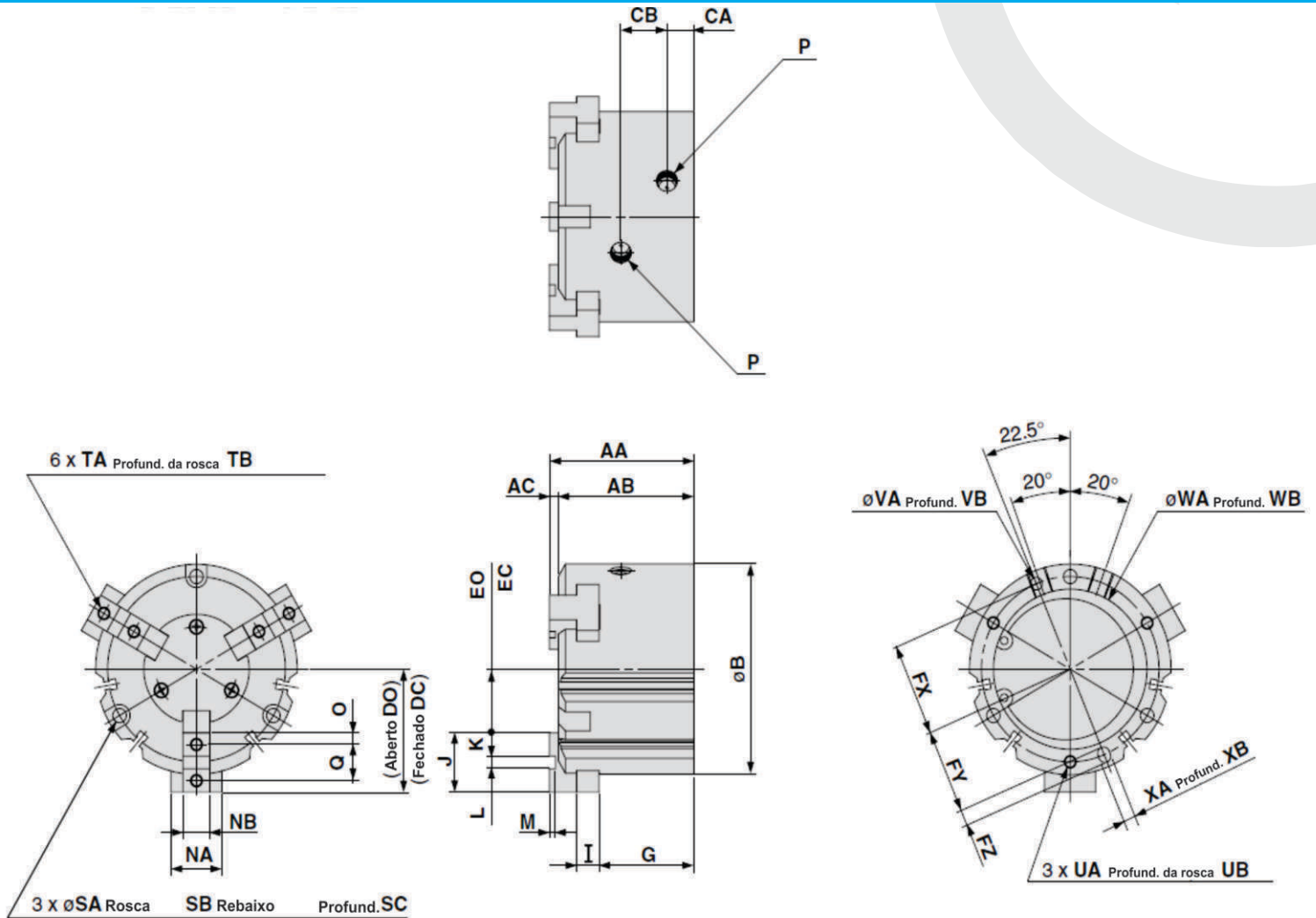

(mm)

Modelo	AA	AB	AC	B	CA	CB	DC	DO	EC	EO	FX	FY	FZ	G	I	J	K	L	M	NA	NB
CHS3-100D	96	90	6	134	18	30.6	66	78	28	40	59	54	10	63	15	38	15	8H9	4	34	18h9
CHS3-125D	122	114	8	166	23.5	38	82	98	30	46	74	68	12	84	18	52	21	10H9	6	40	22h9

Modelo	O	P	Q	R	SA	SB	SC	TA	TB	UA	UB	VA	VB	WA	WB	XA	XB
CHS3-100D	7.5	G 1/4"	23	118	9	14	21	M8 x 1.25	16	M8 x 1.25	16	8H9	6	102H9	4	8H9	6
CHS3-125D	10.5	G 3/8"	31	148	11	17.5	34	M10 x 1.5	20	M10 x 1.5	20	10H9	8	130H9	6	10H9	8

Dimensional - Canal do sensor

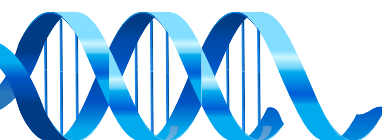
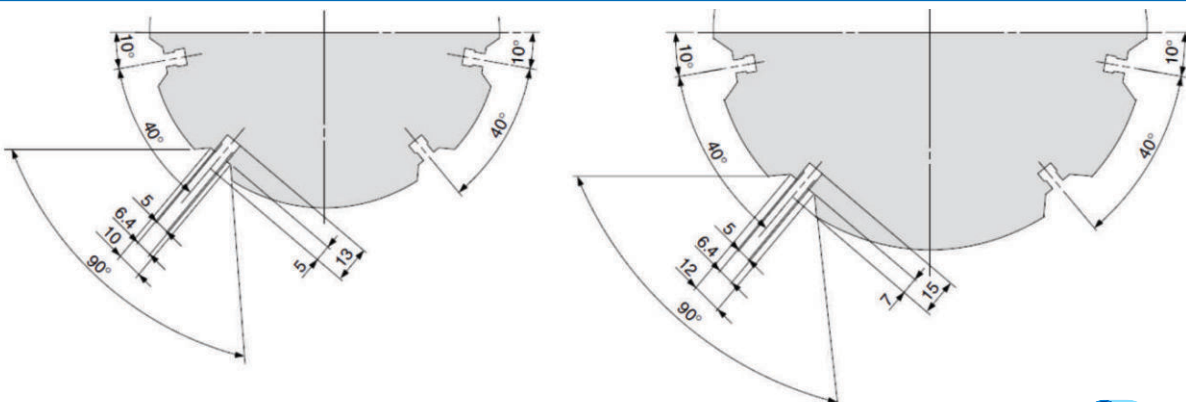



GHPC®

Tecnologia em Produtos Pneumáticos

Detalhamento de montagem da extremidade da placa

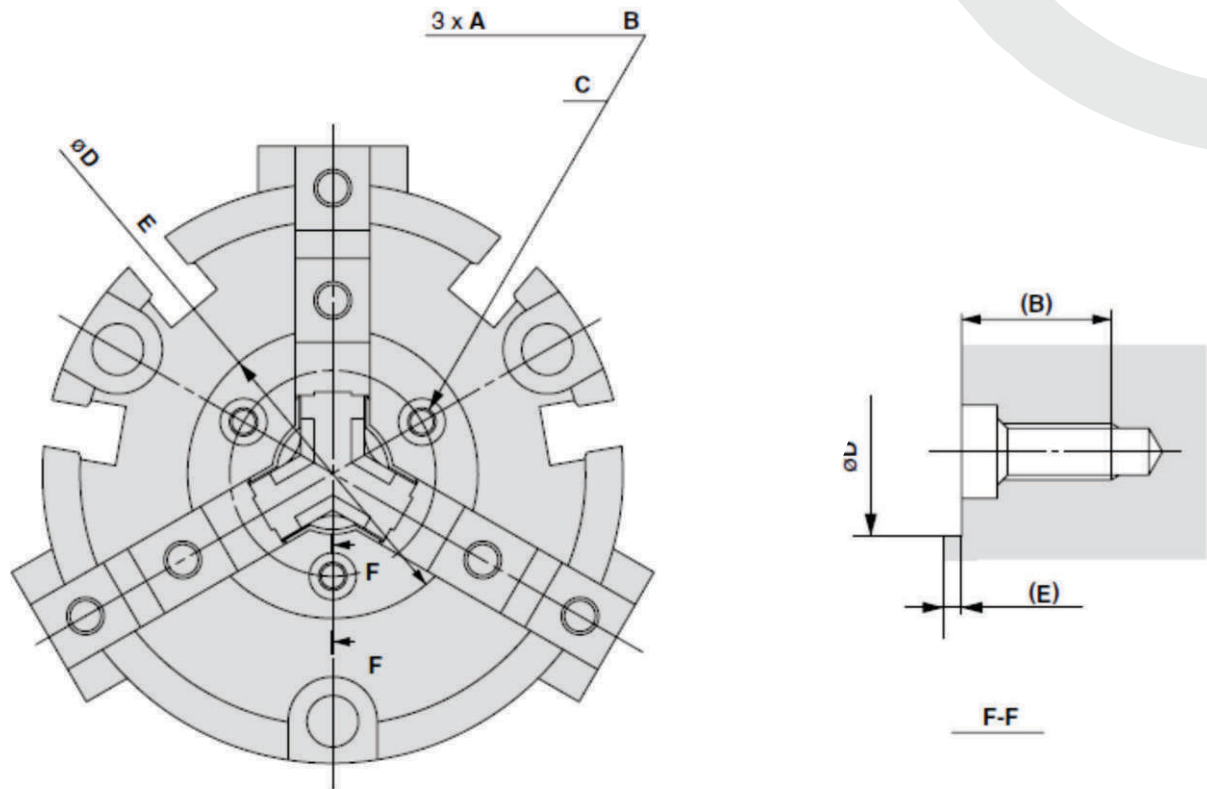

(mm)

Modelo	A	B	C	ØD	E
CHS3-16D	M2 x 0.4	5.5	12.5	18H8	0.5
CHS3-20D		5.4	15	21H8	0.6
CHS3-25D			17	23H8	0.8
CHS3-32D		5.2	21	27H8	
CHS3-40D	M3 x 0.5	8	22	31H8	1
CHS3-50D			26	35H8	
CHS3-63D			33	42H8	
CHS3-80D	M4 x 0.7	9.5	40	52H8	1.5
CHS3-100D			54	70H8	
CHS3-125D			62	82H8	

