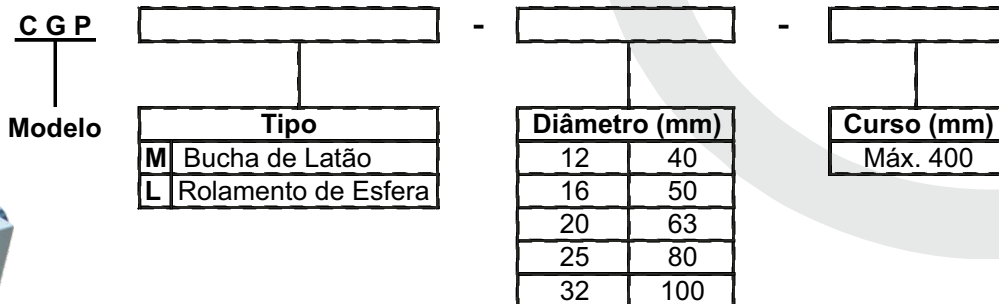
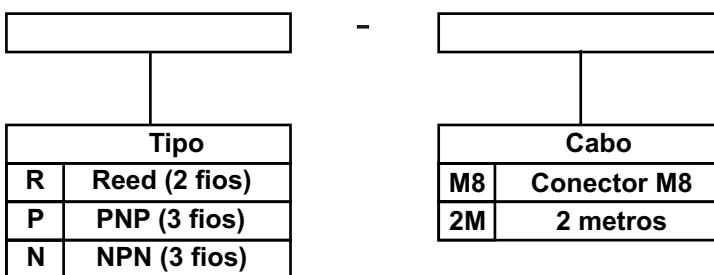
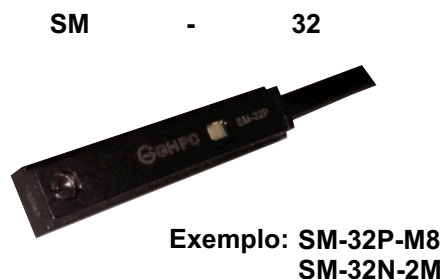

Atuador Pneumático Guiado - Série CGP

Exemplo: **CGPM12-100**
CGPL25-50

Características Técnicas

Diâmetro do Cilindro (mm)	12	16	20	25	32	40	50	63	80	100
Pressão de trabalho (bar)	1 ~ 10									
Temp. de trabalho (°C)	-10 ~ 60									
Velocidade (mm/s)	50 ~ 500									
Rosca de Alimentação	M5 x 0.8			G1/8"			G1/4"		G3/8"	

Sensor Aplicável

Kit de Reparo

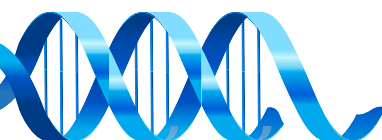
Ø do Cilindro	Código	Compõem o Kit
12	KR-CGP12	Vedação do êmbolo; Vedação da haste; Vedações das tampas.
16	KR-CGP16	
20	KR-CGP20	
25	KR-CGP25	
32	KR-CGP32	
40	KR-CGP40	
50	KR-CGP50	
63	KR-CGP63	
80	KR-CGP80	
100	KR-CGP100	





GHPC®

Tecnologia em Produtos Pneumáticos

Atuador Pneumático Guiado - Série CGP

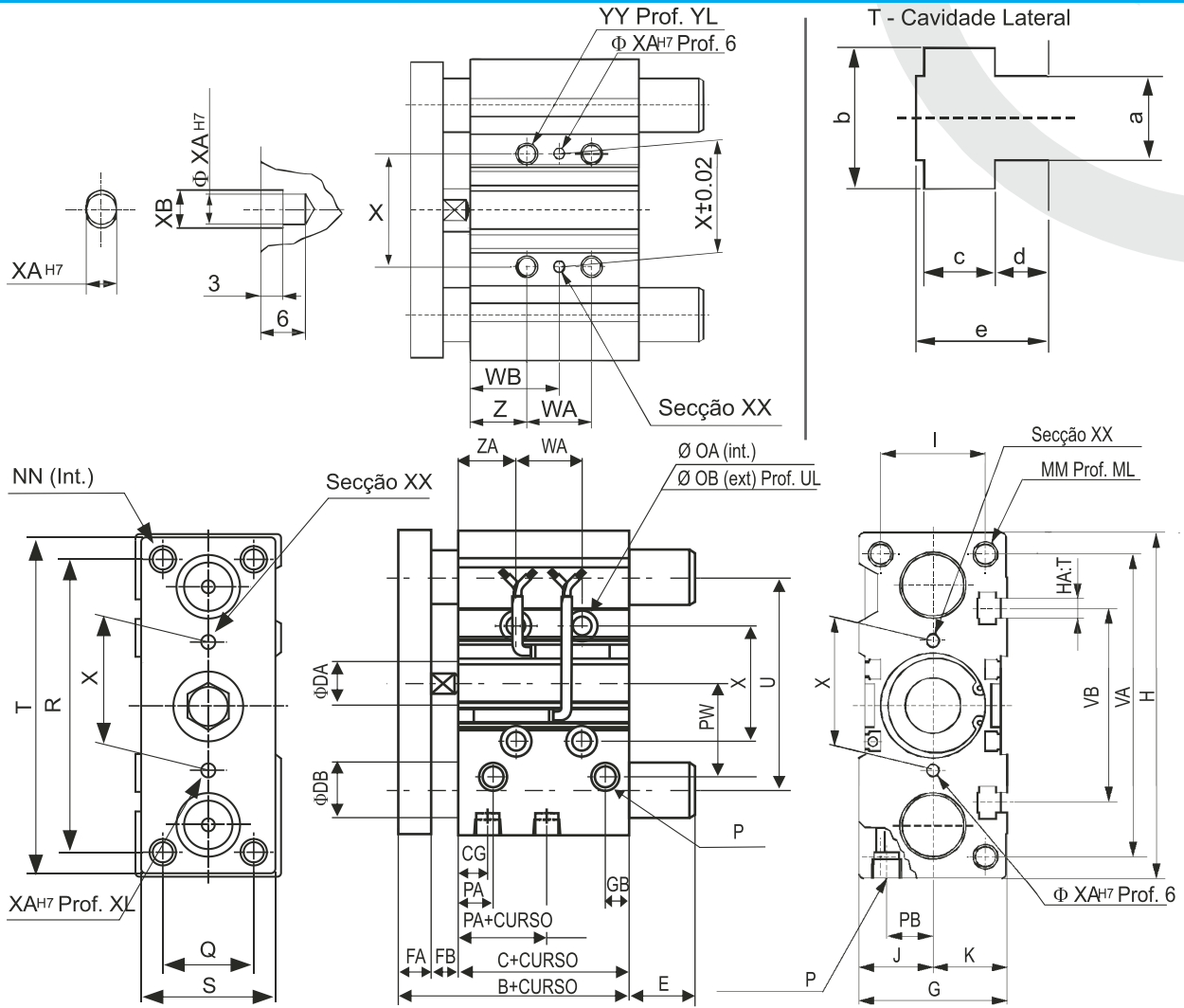

Ø do Cil (mm)	Cursos Padrões	B	C	DA	FA	FB	G	GA	GB	H	HA	J	K	L	MM	ML	NN	AO	OB	P	PA	PB	PW
12	10, 20, 30, 40, 50, 75, 100,	42	29	6	8	5	26	11	7.5	58	M4	13	13	18	M4 X 0.7	10	M4 X 0.7	4.3	8	M5 X 0.8	13	8	18
16	125, 150, 175, 200, 250.	46	33	8	8	5	30	11	8	64	M4	15	15	22	M5 X 0.8	12	M5 X 0.8	4.3	8	M5 X 0.8	15	10	19
20	20, 30, 40, 50, 75, 100, 125, 150,	53	37	10	10	6	36	10.5	8.5	83	M5	18	18	24	M5 X 0.8	13	M5 X 0.8	5.6	9.5	1/8"	12.5	10.5	25
25	175, 200, 250, 300, 350, 400.	53.5	37.5	12	10	6	42	11.5	9	93	M5	21	21	30	M6 X 1.0	15	M6 X 1.0	5.6	9.5	1/8"	12.5	13.5	28.5

Ø do Cil (mm)	Q	R	S	T	U	VA	VB	WA					WB					X	XA	XB	YY	Z
								30 ou -	30 - 100	100 a 200	200 a 300	Acima de 300	30 ou -	30 - 100	100 a 200	200 a 300	Acima de 300					
12	14	48	22	56	41	50	37	20	40	110	200	-	15	25	60	105	-	23	3	3.5	M5 X 0.8	5
16	16	54	25	62	46	56	38	24	44	110	200	-	17	27	60	105	-	24	3	3.5	M5 X 0.8	5
20	18	70	30	81	54	72	44	24	44	120	200	300	29	39	77	117	167	28	3	3.5	M6 X 1.0	17
25	26	78	38	91	64	82	50	24	44	120	200	300	29	39	77	117	167	34	4	4.5	M6 X 1.0	17

CGPM (Bucha de Latão)							
Ø do Cil (mm)	A			DB	E		
	50 ou -	50 - 100	Acima de 100		50 ou -	50 - 100	Acima de 100
12	42	60.5	85	8	0	18.5	43
16	46	64.5	95	10	0	18.5	49
20	53	84.5	112	12	0	31.5	69
25	53.5	85	112	16	0	31.5	68.5

CGPL (Rolamento de Esfera)							
Ø do Cil (mm)	A			DB	E		
	30 ou -	30 - 100	Acima de 100		30 ou -	30 - 100	Acima de 100
12	43	55	85	6	1	13	43
16	49	65	95	8	3	19	49

Ø do Cil (mm)	A				DB	E			
	30 ou -	30 - 100	100 - 200	Acima de 200		30 ou -	30 - 100	100 - 200	Acima de 200
20	63	80	104	122	10	27	27	51	69
25	69.5	85.5	104.5	122	16	32	32	51	68.5

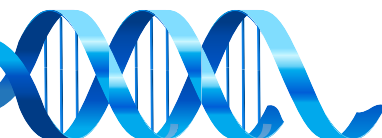

Atuador Pneumático Guiado - Série CGP

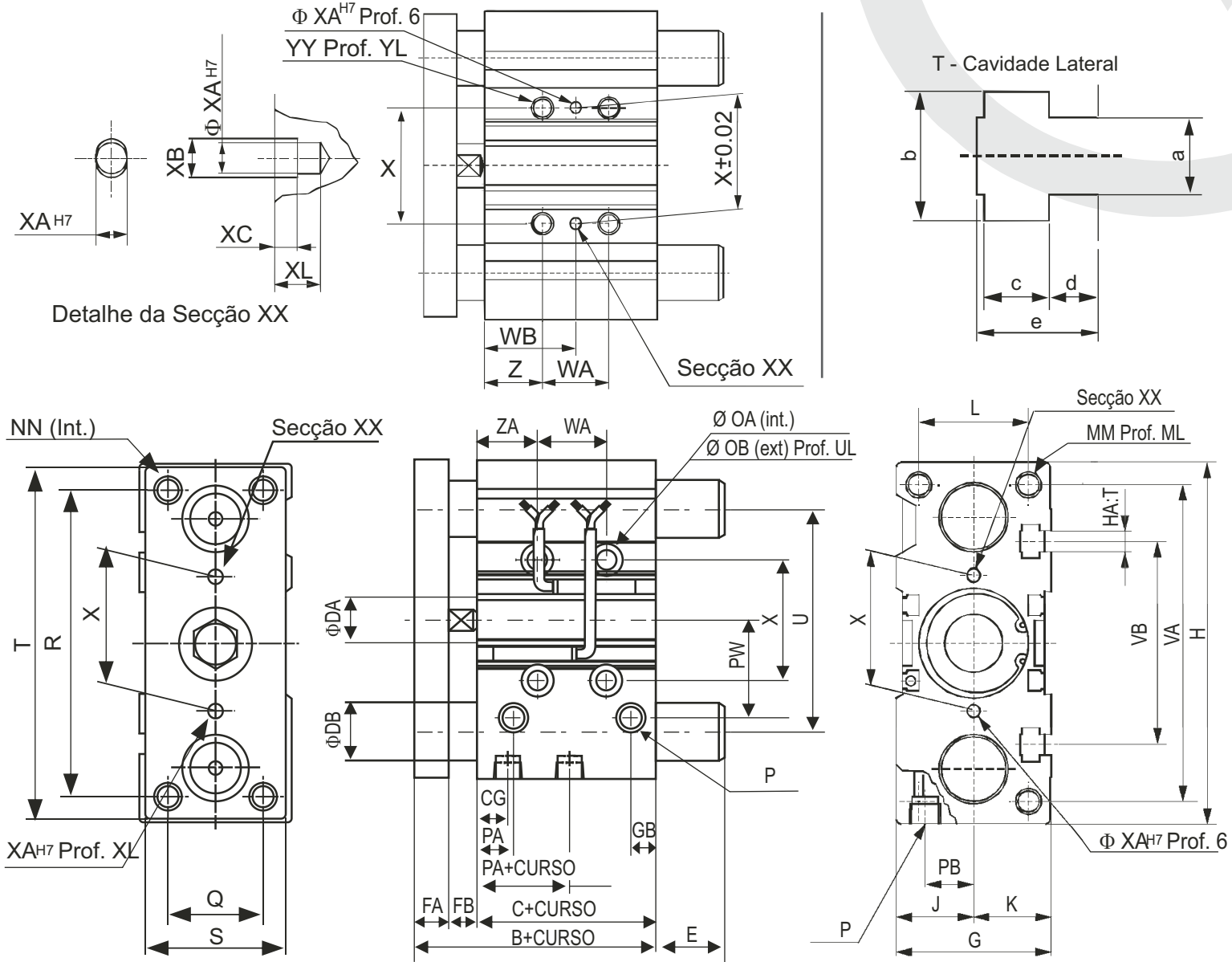

Cursos Padrões	B	C	DA	FA	FB	G	GA	GB	H	HA	J	K	L	MM	ML	NN	AO	OB	P	PA	PB	PW
25, 50, 75, 100, 125, 150, 175, 200, 250, 300, 350, 400	59.5	37.5	16	12	10	48	12.5	9	112	M6	24	24	34	M8 X 1.25	20	M8 X 1.25	6.6	11	1/8"	7	15	34
	66	44	16	12	10	54	14	10	120	M6	27	27	40	M8 X 1.25	20	M8 X 1.25	6.6	11	1/8"	13	18	38
	72	44	20	16	12	64	14	11	148	M8	32	32	46	M10 X 1.5	22	M10 X 1.5	8.6	14	1/4"	9	21.5	47
	77	49	20	16	12	78	16.5	13.5	162	M10	39	39	58	M10 X 1.5	22	M10 X 1.5	8.6	14	1/4"	14	28	55

Ø do Cil (mm)	Q	R	S	T	U	VA	VB	WA						WB										
								25 ou - 25 - 100		100 a 200		200 a 300		Acima de 300		25 ou - 25 - 100		100 a 200		200 a 300		Acima de 300		
								X	XA	XB	XC	XL	YY	Z	X	XA	XB	XC	XL	YY	Z			
32	30	96	44	110	78	98	63	24	48	124	200	300	33	45	83	121	171	42	4	4.5	3	6	M8 X 1.25	21
40	30	104	44	118	86	106	72	24	48	124	200	300	34	46	84	122	172	50	4	4.5	3	6	M8 X 1.25	22
50	40	130	60	146	110	130	92	24	48	124	200	300	36	48	86	124	174	66	5	6	4	8	M10 X 1.5	24
63	50	130	70	158	124	142	110	28	52	128	200	300	38	50	88	124	174	80	5	6	4	8	M10 X 1.5	24

CGPM (Buchta de Latão)

Ø do Cil (mm)	A			DB	E		
	50 ou - 50 - 100		Acima de 100		50 ou - 50 - 100		Acima de 100
	50 ou - 50 - 100	Acima de 100	50 ou - 50 - 100		Acima de 100		
32	97	102	140	20	37.5	42.5	80.5
40	97	102	140	20	31	36	74
50	106.5	118	161	25	34.5	46	89
63	106.5	118	161	25	29.5	41	84

CGPL (Rolamento de Esfera)

Ø do Cil (mm)	A				DB	E			
	30 ou - 30 - 100		Acima de 100			30 ou - 30 - 100		Acima de 100	
	30 ou - 30 - 100	Acima de 100	30 ou - 30 - 100	Acima de 100		30 ou - 30 - 100	Acima de 100		
32	81	98	118	140	16	21.5	38.5	58.5	80.5
40	81	98	140	140	16	15	32	52	74
50	93	114	161	161	20	21	42	62	89
63	93	114	161	161	20	16	37	57	87

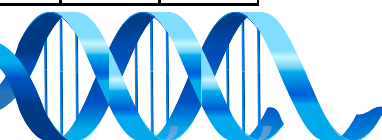

Atuador Pneumático Guiado - Série CGP

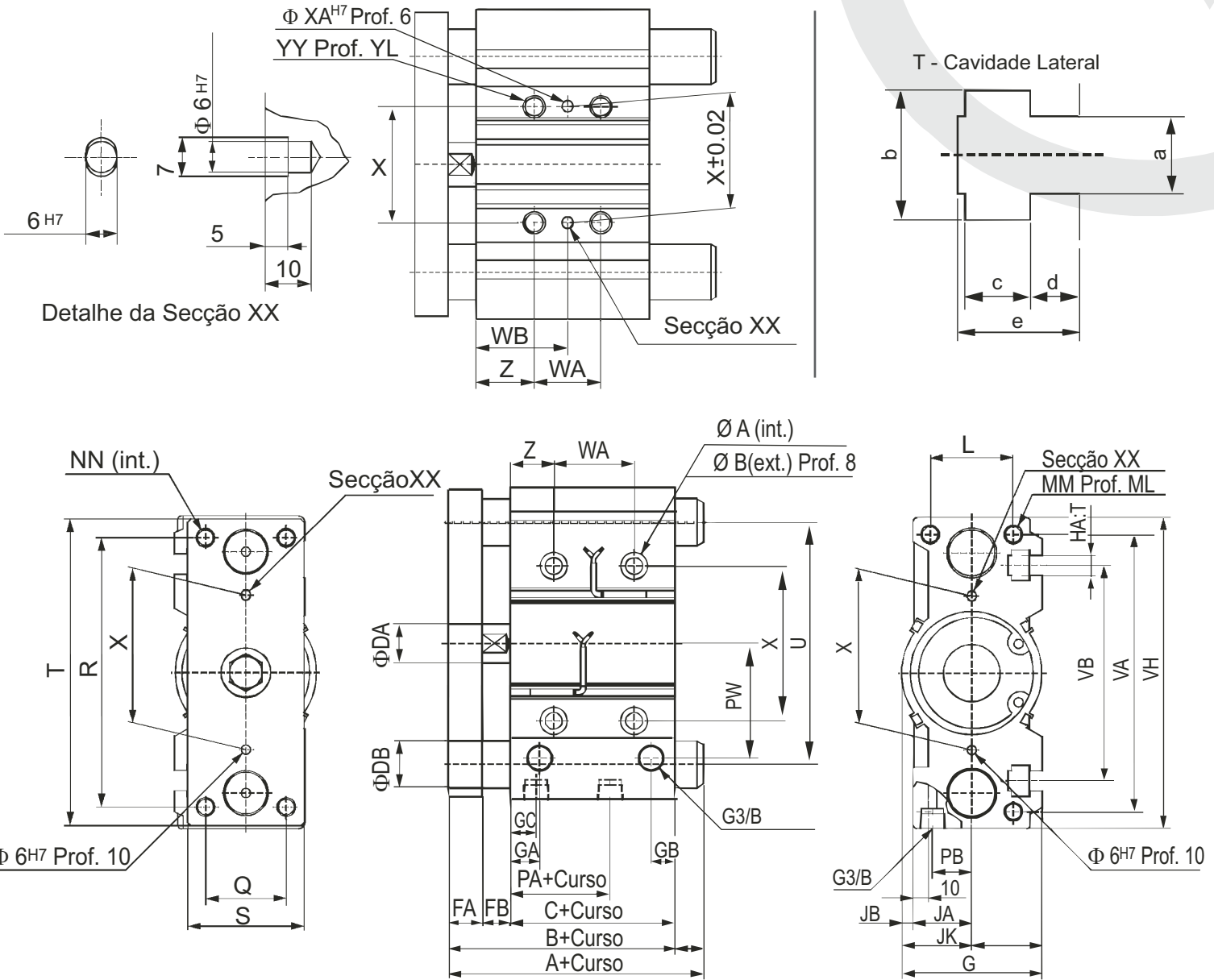

Ø do Cil (mm)	Cursos Padrões	B	C	DA	FA	FB	G	GA	GB	GC	H	HA	J	K	L	MM	ML	NN	AO	OB	OL	P	PA	PB	PW
80	25, 50, 75, 100, 125, 150, 175, 200, 250, 300, 350, 400	96.5	56.6	25	22	18	91.5	19	15.5	14.5	202	M12	45.5	38	7.5	46	54	M12 X 1.75	25	M12 X 1.75	10.6	17.5	14.5	25.5	74
100		116	66	30	25	25	111.5	23	19	17.5	240	M14	55.5	45	10.5	56	62	M14 X 2.0	31	M14 X 2.0	12.5	20	17.5	32.5	89

Ø do Cil (mm)	Q	R	S	T	U	VA	VB	WA			WB			X	YY	Z				
								25 ou -	25 - 100	100 a 200	200 a 300	Acima de 300	25 ou -				25 - 100	100 a 200	200 a 300	Acima de 300
80	52	174	75	198	156	180	140	28	52	128	200	300	42	54	92	128	178	100	M12 X 1.75	28
100	64	210	90	236	188	210	166	11	72	148	220	320	35	47	85	121	171	124	M14 X 2.0	11

CGPM (Buchta de Latão)

Ø do Cil (mm)	A			DB	E		
	50 ou -	50 - 100	Acima de 100		50 ou -	50 - 100	Acima de 100
80	115	142	193	30	18.5	45.5	96.5
100	137	162	203	36	21	46	87

CGPL (Rolamento de Esfera)

Ø do Cil (mm)	A				DB	E			
	25 ou -	25 - 50	50 - 200	Acima de 200		25 ou -	25 - 50	50 - 200	Acima de 200
80	109.5	130	160	193	25	13	33.5	63.5	96.5
100	121	147	180	203	30	5	31	64	87

